

# URBANFIT NITRO CENTURION

>> UFN - 6009



## ↓ DOWNLOADS



Login or Register to access to DWG files and large product images.

\*Estimate based on normal lead times and delivery for manufactured products within Australia. To view our range of spare parts, please visit [playgroundparts.com.au](http://playgroundparts.com.au)

## SPECIFICATIONS

Fall Height	1150mm
Product Dimensions	7m x 1.3m 2.5m(H)
Total Space Required	33m <sup>2</sup> (10m x 4m)

## USAGE

 Flexibility  Strength  Resistance

## TECHNICAL INFORMATION

AUS Standards Compliance	AS 16630:2021
Assembly Time	12 hrs
Total Weight	213 kg
Heaviest Component	47 kg
Concrete Required	0.5 m <sup>3</sup>
Number of Footings	6
Foundations	Info on application
Largest Part	Info on application
Spare Parts Availability	4-6 weeks*

URBANFIT NITRO  
**CENTURION**

» UFN - 6009



**SIDE AND TOP ELEVATION**

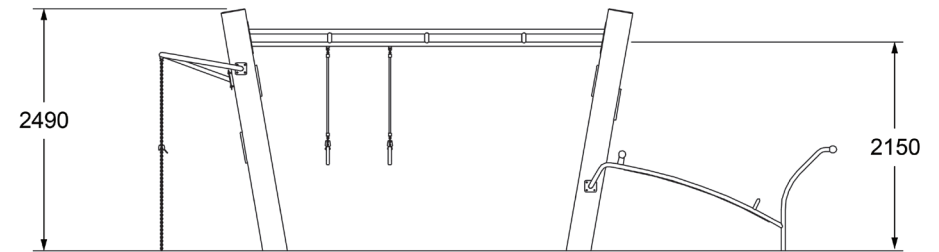
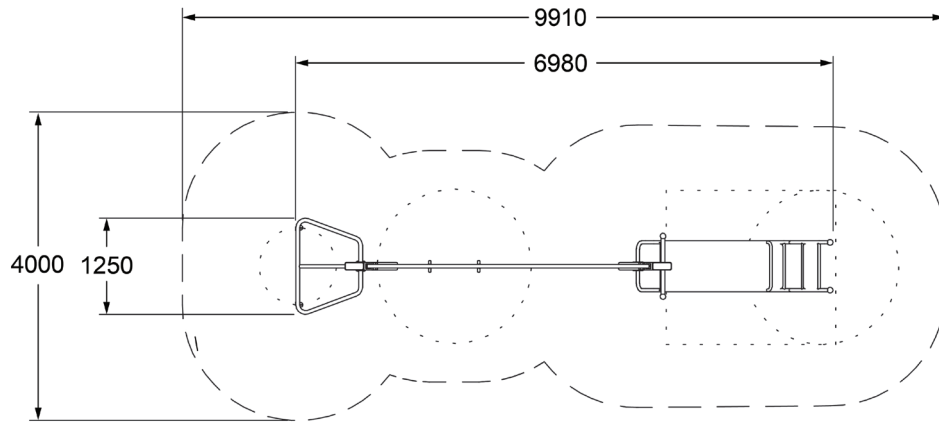

For information on our [Care Plan](#), or [Warranty](#), please contact Moduplay Group Pty Ltd:

**P.** 1800 806 145 **P.** +612 4272 1644 **E.** [info@urbanfit.com.au](mailto:info@urbanfit.com.au) **A.** 12-14 Doyle Avenue Unanderra NSW 2526 Australia

**URBANFIT**  
by MODUPLAY