

URBANFIT NITRO

TITAN

>> UFN - 6003



↓ DOWNLOADS

Login or Register to access to DWG files and large product images.

*Estimate based on normal lead times and delivery for manufactured products within Australia. To view our range of spare parts, please visit playgroundparts.com.au

SPECIFICATIONS

Fall Height	1150mm
Product Dimensions	1.2m x 4m x 2.5m(H)
Total Space Required	23.6m ² (4.1m x 7m)

USAGE

 Flexibility  Strength

TECHNICAL INFORMATION

AUS Standards Compliance	AS 16630:2021
Assembly Time	6 hrs
Total Weight	132 kg
Heaviest Component	61 kg
Concrete Required	0.3 m ³
Number of Footings	5
Foundations	Info on application
Largest Part	Info on application
Spare Parts Availability	4-6 weeks*

URBANFIT NITRO

TITAN

» UFN - 6003



SIDE AND TOP ELEVATION

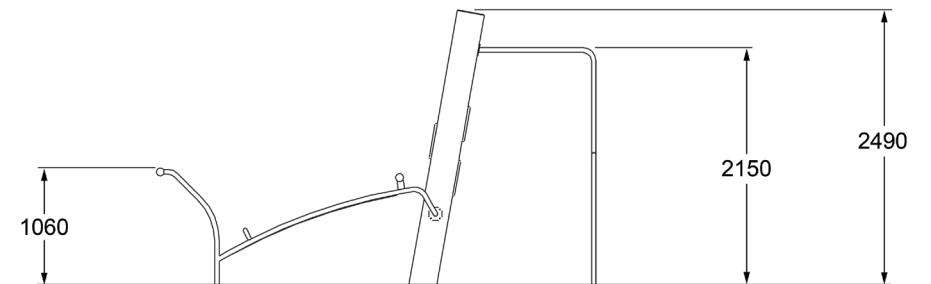
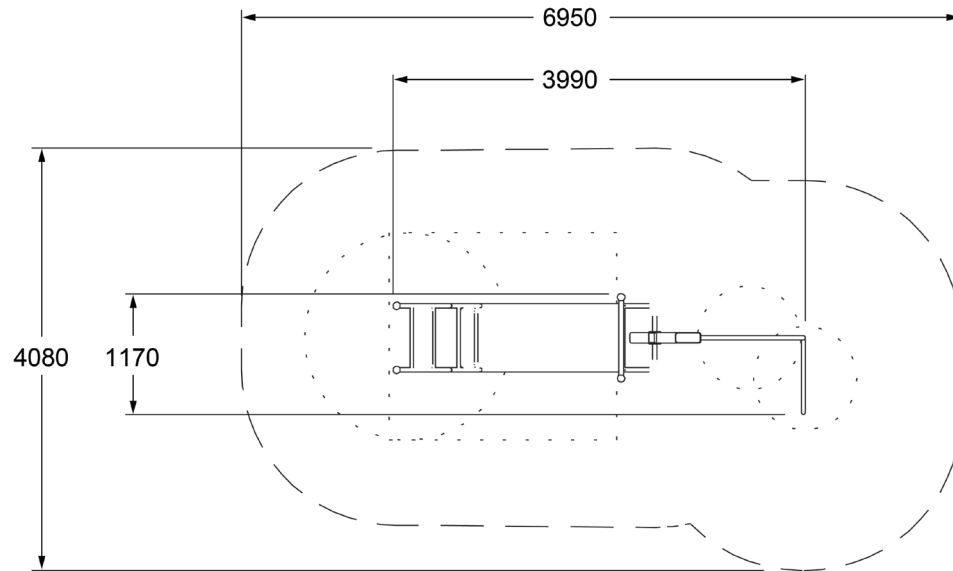

For information on our [Care Plan](#), or [Warranty](#), please contact Moduplay Group Pty Ltd:

P. 1800 806 145 **P.** +612 4272 1644 **E.** info@urbanfit.com.au **A.** 12-14 Doyle Avenue Unanderra NSW 2526 Australia

URBANFIT
by MODUPLAY