

URBANFIT **ACTIVO**

CORE TWISTA DOUBLE

>> UFE - 6219



↓ DOWNLOADS

Login or Register to access to DWG files and large product images.

*Estimate based on normal lead times and delivery for manufactured products within Australia. To view our range of spare parts, please visit playgroundparts.com.au

SPECIFICATIONS

Fall Height	140mm
Product Dimensions	0.4m x 1.4m x 1.7m(H)
Total Space Required	12.3m ² (3.4m x 4.4m)

USAGE

 Flexibility  Strength  Balance

TECHNICAL INFORMATION

AUS Standards Compliance	AS 16630:2021
Assembly Time	2 hrs
Total Weight	65 kg
Heaviest Component	48 kg
Concrete Required	0.2 m ³
Number of Footings	3
Foundations	Info on application
Largest Part	Info on application
Spare Parts Availability	4-6 weeks*

URBANFIT **ACTIVO**

CORE TWISTA DOUBLE

>> UFE - 6219



SIDE AND TOP ELEVATION

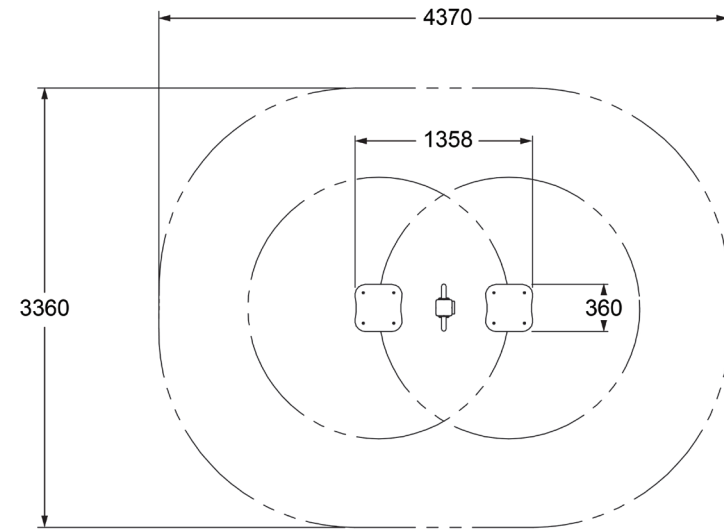
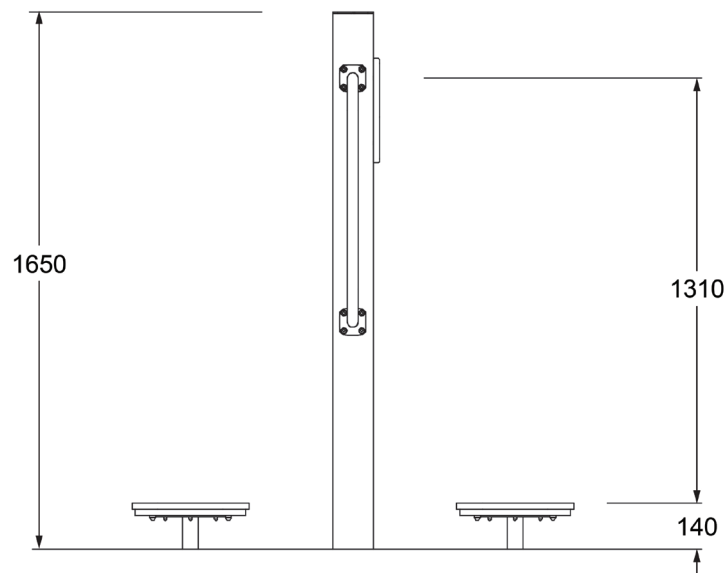

For information on our [Care Plan](#), or [Warranty](#), please contact Moduplay Group Pty Ltd:

P. 1800 806 145 **P.** +612 4272 1644 **E.** info@urbanfit.com.au **A.** 12-14 Doyle Avenue Unanderra NSW 2526 Australia

URBANFIT
by MODUPLAY