

URBANFIT **ACTIVO**

LAT PULL-DOWN

>> UFE - 6202



↓ DOWNLOADS

Login or Register to access to DWG files and large product images.

*Estimate based on normal lead times and delivery for manufactured products within Australia. To view our range of spare parts, please visit playgroundparts.com.au

SPECIFICATIONS

Fall Height	620mm
Product Dimensions	1.1 m x 0.8m x 2.4m(H)
Total Space Required	11.5m ² (4.1 m x 3.8m)

USAGE

 Strength

TECHNICAL INFORMATION

AUS Standards Compliance	AS 16630:2021
Assembly Time	2 hrs
Total Weight	89 kg
Heaviest Component	89 kg
Concrete Required	0.2 m ³
Number of Footings	1
Foundations	Info on application
Largest Part	Info on application
Spare Parts Availability	4-6 weeks*

URBANFIT **ACTIVO**

LAT PULL-DOWN

>> UFE - 6202



SIDE AND TOP ELEVATION

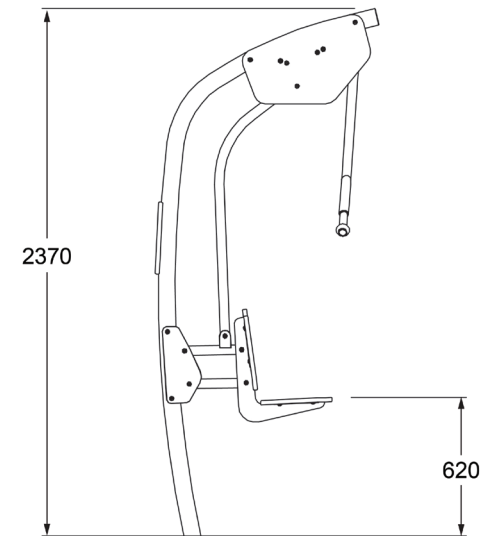
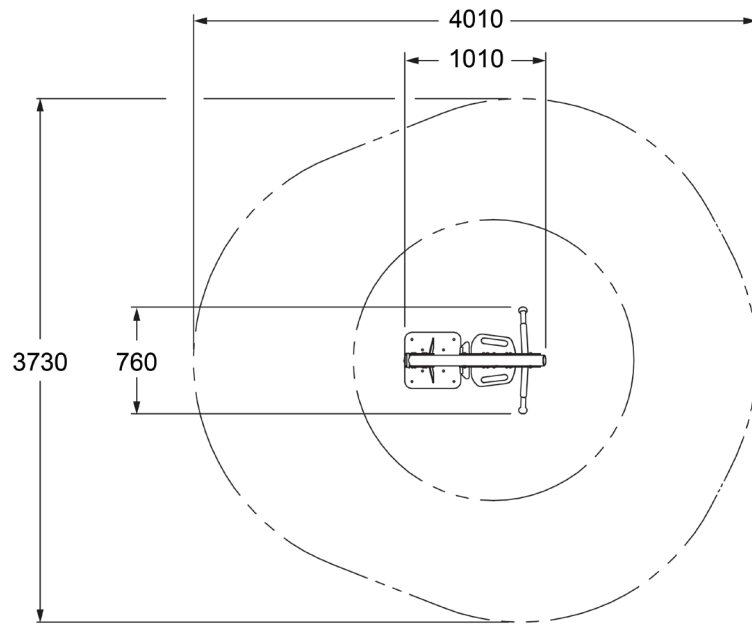

For information on our [Care Plan](#), or [Warranty](#), please contact Moduplay Group Pty Ltd:

P. 1800 806 145 **P.** +612 4272 1644 **E.** info@urbanfit.com.au **A.** 12-14 Doyle Avenue Unanderra NSW 2526 Australia

URBANFIT
by MODUPLAY