

URBANFIT TREKKO

STATIC BENCH

>> UFT-3631



↓ DOWNLOADS

Login or Register to access to DWG files and large product images.

*Estimate based on normal lead times and delivery for manufactured products within Australia. To view our range of spare parts, please visit playgroundparts.com.au

SPECIFICATIONS

| | |
|----------------------|----------------------------------|
| Fall Height | 460mm |
| Product Dimensions | 2.5m x 0.3m x 0.5m(H) |
| Total Space Required | 15.8m ² (5.4m x 3.3m) |

USAGE

 Strength  Cardio

TECHNICAL INFORMATION

| | |
|--------------------------|---------------------|
| AUS Standards Compliance | AS 16630:2021 |
| Assembly Time | 1.5 hrs |
| Total Weight | 29 kg |
| Heaviest Component | 11.5 kg |
| Concrete Required | 0.2 m ³ |
| Number of Footings | 2 |
| Foundations | Info on application |
| Largest Part | Info on application |
| Spare Parts Availability | 4-6 weeks* |

URBANFIT TREKKO
STATIC BENCH

>> UFT-3631



SIDE AND TOP ELEVATION

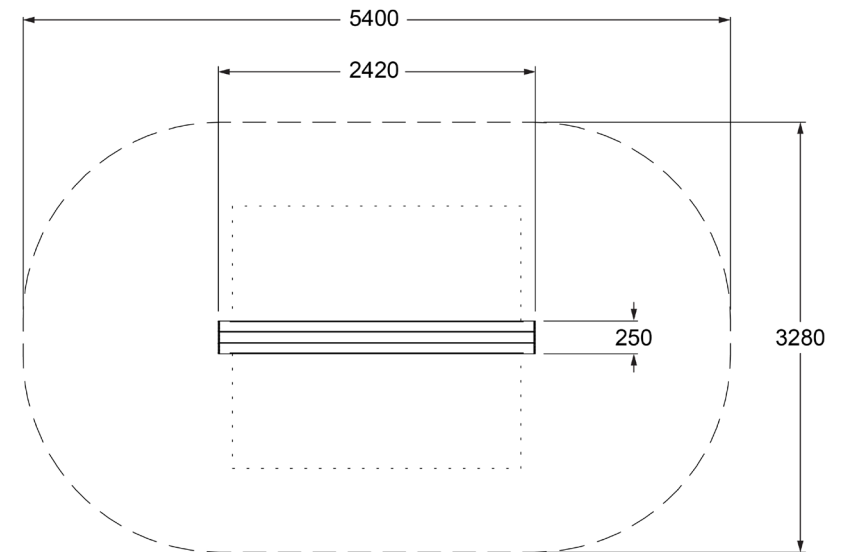
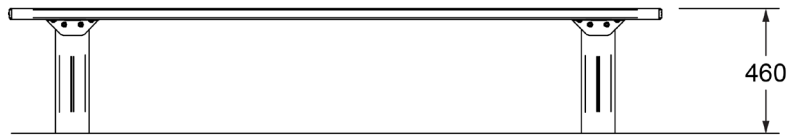

For information on our [Care Plan](#), or [Warranty](#), please contact Moduplay Group Pty Ltd:

P. 1800 806 145 **P.** +612 4272 1644 **E.** info@urbanfit.com.au **A.** 12-14 Doyle Avenue Unanderra NSW 2526 Australia

URBANFIT
by MODUPLAY